



**L3HARRIS™**  
FAST. FORWARD.

## P/N 45510

### 8" C-/E-Band Spiral Antenna

To meet the expanding applications of communications, electronic warfare, telemetry and many other defense and communications requirements, L3Harris' series of planar spiral antennas used for detection of broadband signals having various polarizations.

The 8" model 45510 antenna is a rugged, flight qualified, cavity-backed two-arm Archimedean spiral. A Marchand balun is used to connect the spiral aperture card to the output connector. This element features a minimum cavity depth and excellent low frequency pattern control performance.

Designed for RWR Direction Finding (DF) applications, the characteristics of this antenna also make it an ideal choice for a phase-tracking interferometer element, SIGINT antenna and any application requiring frequency independent performance. Phase tracking among 10 units was found to be better than 2° RMS on boresite.

The VSWR is typically less than 1.5:1 over the majority of the band. Power handling is typically 10 Watts CW. Actual performance depends on installation and environmental conditions. The antenna can be provided with or without an aperture environmental radome cover.



#### PHYSICAL DIMENSIONS (TYPICAL UNIT)

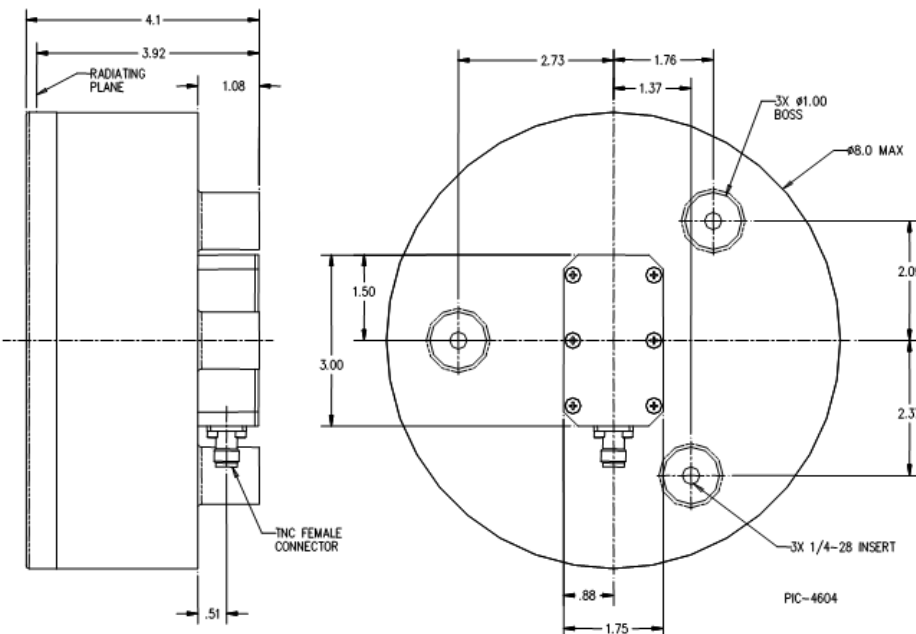

WEIGHT: 2.2 lbs.

#### KEY FEATURES

- > 0.5–4.0 GHz Frequency Operation
- > Right or Left Circular Polarization
- > Designed for RWR Application
- > Designed for Military Airborne Environment

## TYPICAL MEASURED PERFORMANCE

Performance varies with radome design, manufacturing tolerances, installation, and environmental conditions. Data shown is typical for the antenna without radome.

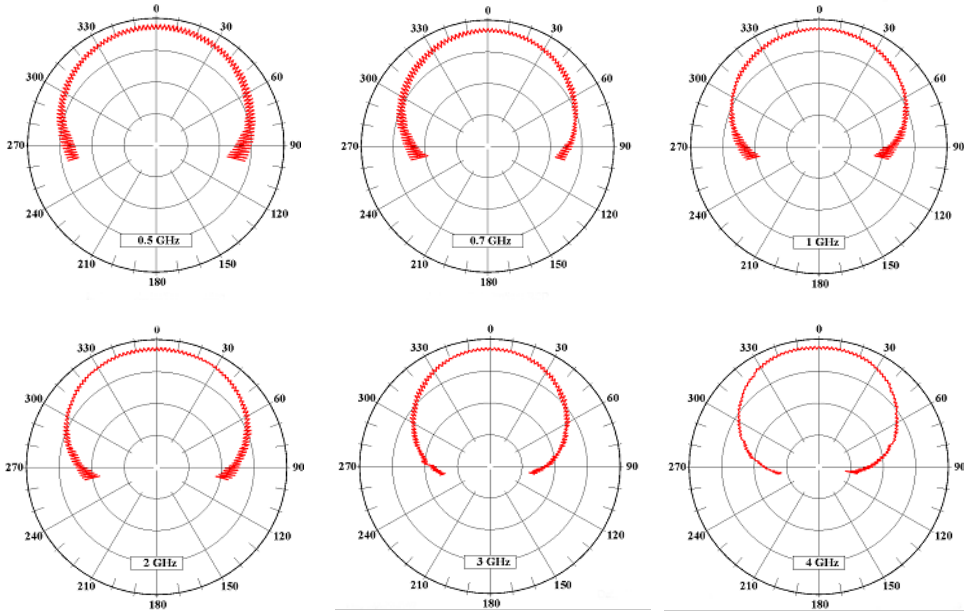

Azimuth Radiation Pattern Response to Rotating Linear Polarization (10 dB Rings)

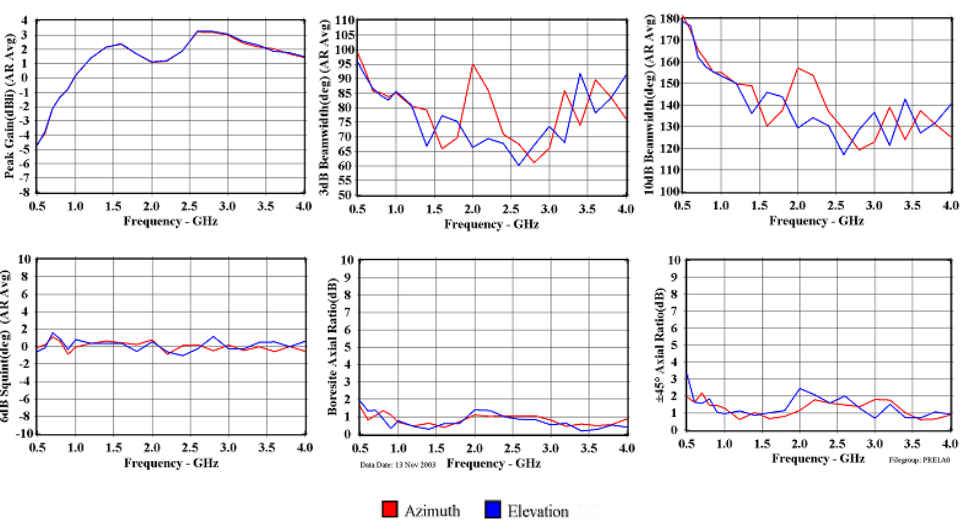

Antenna Performance Summary

P/N 45510

© 2021 L3Harris Technologies, Inc. | 08/2021

**PUBLIC RELEASE.** Cleared by DoD/OSR for public release under 07-S-1153 on November 18, 2014.

Data, including specifications contained within this document, are summary in nature and subject to change at any time without notice at L3Harris Technologies' discretion. All brand names and product names referenced are registered trademarks, or trade names of their respective holders. Use of U.S. DoD visual information does not imply or constitute DoD endorsement.

L3Harris Technologies is an agile global aerospace and defense technology innovator, delivering end-to-end solutions that meet customers' mission-critical needs. The company provides advanced defense and commercial technologies across air, land, sea, space and cyber domains.



1025 W. NASA Boulevard  
Melbourne, FL 32919  
t 866 900 7270 | f 650 326 1033  
Antennas@L3Harris.com