

MODULAR PAYLOAD COMPLIANT BANSHEE™ TRANSCEIVER

Protected, assured communications and networking for airborne and maritime platforms

L3Harris' Modular Payload Compliant Banshee (MPCB) provides protected and robust mesh networking for airborne and air-to-ground/maritime connectivity. The MPCB's assured position, navigation and timing (APNT) capabilities strengthen resiliency in contested communications environments.

PRODUCT DESCRIPTION

The first-generation BANSHEE Transceiver was designed to provide a robust, protected data link, enabling coordinated swarming UAVs to operate unimpeded in spectrally contested and congested environments. It is a low-cost secure radio, hosting advanced features of L3Harris' Advanced Tactical Data Link (ATDL) 1.0 Waveform and Network Technology.

The L3Harris MPCB includes all of the features of the first-generation BANSHEE in a form factor designed to meet the requirements for EW/SIGINT/Communications systems for Class 1-3 UAS, manned aircraft, and small maritime vessels as detailed in USSOCOM SAFC document MOD PAYLOAD, Revision 5.1, May 25, 2021. MPCB provides the advantages of ATDL 1.0 connectivity and APNT capabilities to platforms that support the Mod Payload standard.

The MPCB's Topology Manager supports advanced mesh networking features through a distributed mesh, enabling the network to scale from 2 to 32 nodes in a coordinated flat network. Tiered networks can be employed to extend well beyond 32 nodes. Optimization for real-time network management enable rapid network convergence amid highly dynamic operations. Additionally, the ATDL 1.0 waveform is capable of providing APNT support to platforms in contested environments. Among these features, the waveform's time-transfer/synchronization capabilities allow for highly coordinated operations between networked platforms.



First-generation BANSHEE

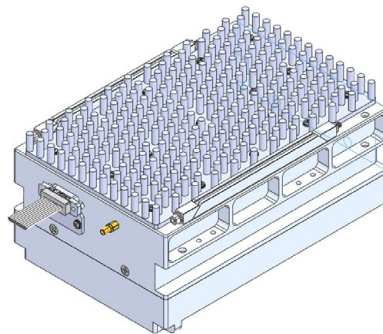

Modular Payload Compliant BANSHEE



Use of U.S. DoD visual information does not imply or constitute DoD endorsement.

Secure and scalable networking for advanced communications resiliency, electronic warfare, APNT and swarming applications

KEY NETWORKING FEATURES

- > Scalable mesh network up to 32 nodes
- > Advanced spectral sense-and-react and anti-jam features
- > Low latency
- > Full duplex, 3-channel waveform
- > Authenticated network entry
- > Compatible with omni-directional antennas

OTHER ADVANCED CAPABILITIES

- > Cooperative emitter geolocation
- > GPS denied relative navigation
- > Assured positioning and timing
- > Swarm networking and inter-swarm communication

SPECIFICATIONS

Performance Characteristics

- > Multiband reception and transmission: S- and C-Bands
- > 3-band, reconfigurable operation (1 Tx and 2 Rx)

Waveform Characteristics

- > ATDL Mesh 1.0 compatible
- > Data rates from 4 kbps to 11 Mbps
- > Up to 32 node mesh connectivity
- > Up to 250 knots relative velocity with standard build (1000 knots relative velocity is also available)

Encryption

- > AES (with road map to Type 1)

SWaP

- > Size: 3.01" (h) x 6.25" (l) x 4.29" (w)
- > Weight: 2.91 lbs.
- > RF Power out: 30dBm or 1 Watt
- > Power Consumption: 42 Watts (typical), 52 Watts (max)
- > Input Voltage: 22 to 32 VDC

Environmental

- > Operating Temperature: -25 °C to +49 °C
- > Shock: 100G transient for launch

Networking

- > Up to 5 direct neighbors
- > Up to 32 networked nodes per tier
- > Automated topology optimization
- > Internet Protocol (IP) HW-based routing
- > IP-based quality of service (QoS)

Special Features

- > In-band jammer/interference sensing algorithm
- > Automatic frequency agility
- > Power limiting mode controlled by profile

Applications

- > Coordinated air, ground and maritime operations
- > Mod Payload Compliant aircraft and maritime platforms operating in spectrally congested and contested environments
- > Swarming operations

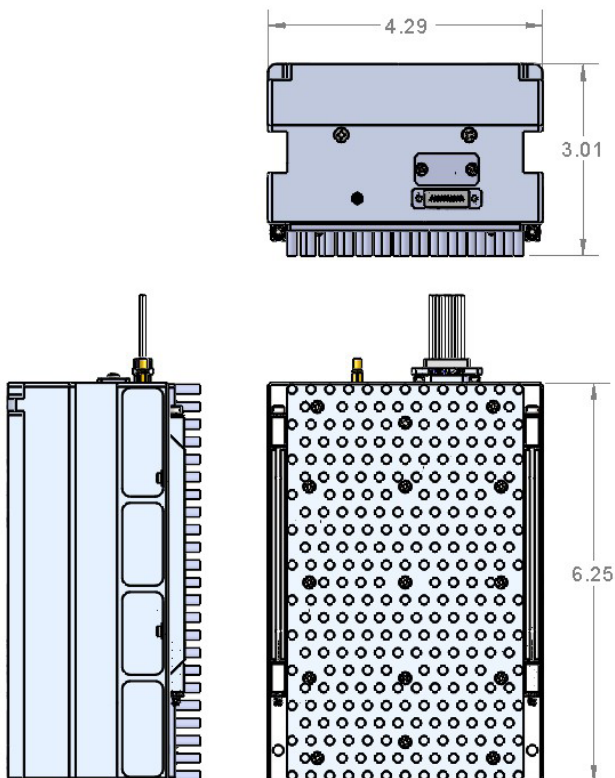

Modular Payload Compliant BANSHEE Transceiver

© 2023 L3Harris Technologies, Inc. | 11/2023 | BCS | 23-DSD-316 | Rev-201

THIS INFORMATION IS APPROVED FOR RELEASE WITHOUT EXPORT RESTRICTIONS IN ACCORDANCE WITH A REVIEW OF THE INTERNATIONAL TRAFFIC IN ARMS REGULATIONS (ITAR), 22CFR 120-130, AND THE EXPORT ADMINISTRATION REGULATIONS (EAR) 15 CFR 730-774.

L3Harris Technologies is the Trusted Disruptor for the global aerospace and defense industry. With customers' mission-critical needs always in mind, our more than 50,000 employees deliver end-to-end technology solutions connecting the space, air, land, sea and cyber domains. L3Harris.com.

Use of U.S. DoD visual information does not imply or constitute DoD endorsement.



1025 W. NASA Boulevard
Melbourne, FL 32919
t 833 537 6837
CSW.Products@L3Harris.com